

INSTALLATION INSTRUCTIONS

OIL HEATERS & REMOTE THERMOSTATS OW / OE SERIES

Hotstart Manufacturing, Inc. is the owner of all trademarks and copyrightable material contained herein; all rights are reserved; no form of reproduction is authorized without prior written consent from Hotstart Manufacturing, Inc.

BEFORE YOU INSTALL

HOTSTART oil heaters are designated as either Weathertight (with the prefix "OW-") or as Class I, Group D (with the prefix "OE-"). Oil heaters must always be installed with the heater probe submerged below the minimum oil level at all times. To maintain oil temperature, HOTSTART recommends using the heater with a remote thermostat. Like the heater probe, the remote thermostat probe must also remain submerged below the minimum oil level to control oil temperature.

CAUTION

Personal Injury: Disconnect power supply before performing any electrical work. Wiring must be performed by a trained technician and in accordance with national and local electrical codes.

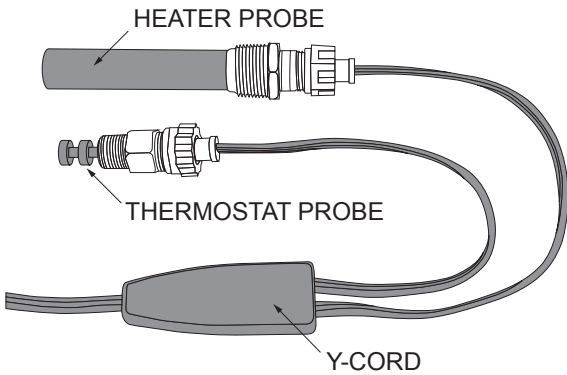

Figure 1. Typical Weathertight oil heater with optional Y-cord. Your model may differ from illustration.

WEATHERTIGHT MODELS

If your Weathertight oil heater is equipped with a remote thermostat attached by a Y-cord, be sure to detach the heater and thermostat from the cord prior to installation. After the heater and thermostat are installed, reattach the Y-cord. See Fig. 1.

CLASS I, GROUP D MODELS

If you are wiring a Class I, Group D remote thermostat with an oil heater for Hazardous Locations, note that the thermostat and heater must be wired in series to regulate temperature. Models designated for Hazardous Locations have a termination enclosure to meet NEC Class I, Division 1, Group D requirements when wired in compliance with NEC specifications. See Fig. 2.

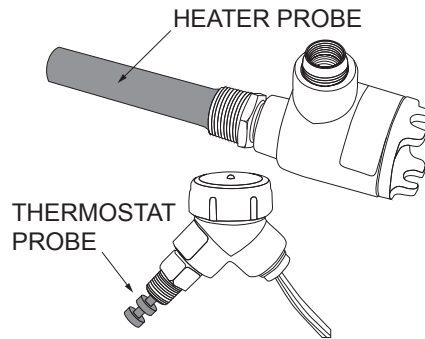

Figure 2. Typical OE series heater with showing heater element, thermostat well and heater cord. Your heater may vary from illustration.

**Corporate & Manufacturing
Headquarters**
5723 E. Alki Ave
Spokane, WA 99212 USA
509.536.8660
sales@hotstart.com

Oil & Gas Office
21732 Provincial Blvd.
Suite 170
Katy, TX 77450 USA
281.600.3700
oil.gas@hotstart.com

Europe Office
HOTSTART GmbH
Am Turm 86
53721 Siegburg, Germany
+49.2241.12734.0
europe@hotstart.com

Asia Pacific Office
HOTSTART Asia Pacific Ltd.
2-27-15-4F Honkomagome
Bunkyo-ku, Tokyo
113-0021, Japan
+81.3.6902.0551
apac@hotstart.com

INSTALLING THE OIL HEATER

If your OLT or OW series heater has already been installed, skip this section and *continue to the* **INSTALLING THE REMOTE THERMOSTAT** section.

NOTICE

Overheating Hazard: Do not install the oil heater above the minimum oil level. A heater element that is not completely submerged can cause overheating and damage the oil.

Overheating Hazard: HOTSTART does not recommend installing the oil heater in the sump drain or with the element in any vertical position. Installing the heater in a vertical position may cause the oil level to fall below the height of the heater element. A heater that is not completely submerged can cause overheating and damage the oil.

Improper Mounting: The wall of the sump must be at least 3/8 inch (10 mm) thick to provide an adequate mounting hole. If the sump wall is too thin, a flange must be installed to mount the heater. Heaters mounted to thin sump walls are vulnerable to vibration damage and may leak or become detached. See Fig. 3 and Fig. 4.

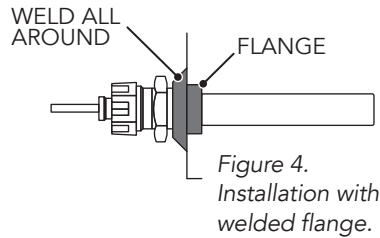
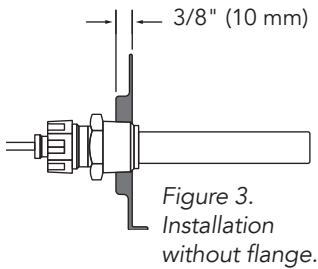

1. If the oil heater is attached to a remote thermostat by a Y-cord, detach heater from the Y-cord.
2. Drain oil sump. If drilling or welding is required, remove oil pan.

3. Install the oil heater low in the side of the oil pan or sump. Do not install heater lower than 1-3/4 inches (44 mm) from the bottom or walls of the sump. Keep heater away from internal objects. See Fig. 5. To find the thread size needed for your heater model, see Table 1.

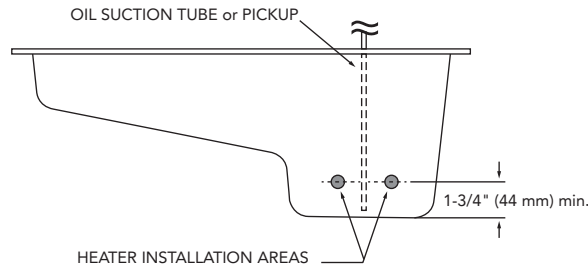

Figure 5. Possible heater installation areas. Keep heater away from objects such as an oil suction tube or pickup.

NOTE: Some manufacturers provide additional openings in the sump. HOTSTART recommends using an available opening if the location is acceptable for heater installation.

4. Reattach the heater plug, per step 1. Screw the hex nut to the heater.

INSTALLING THE REMOTE THERMOSTAT

NOTICE

Overheating Hazard: Do not install the thermostat above the minimum oil level. A thermostat that is not completely submerged will not properly regulate the oil heater. An unregulated heater can cause overheating and damage the oil.

Improper Mounting: The wall of the sump must be at least 3/8 inch (10 mm) thick to provide an adequate mounting hole. If the sump wall is too thin, a flange must be installed to mount the thermostat. Thermostats mounted to thin sump walls are vulnerable to vibration damage and may leak or become detached.

1. Per **INSTALLING THE OIL HEATER** step 2, ensure oil sump is drained. If drilling or welding is required, remove oil pan.

Model	Thread Size	Model	Thread Size	Model	Thread Size	Model	Thread Size
OW0 or OE0	3/8" NPT	OW1	1.0625-12 UN-2A	OWB or OEB	M33 × 2	OWF	M14 × 1.5
OW2 or OE2	1/2" NPT	OW3	1.3125-12 UN-2A	OWC	M36 × 1.5	OWG	M24 × 2
OW4 or OE4	3/4" NPT	OW5	3/4-16 UNF	OWD	M22 × 1.5	OWJ	M18 × 1.5
OW6 or OE6	1" NPT			OWE	M27 × 2		

Table 1. OW/OE series heater thread sizes.

2. Install the thermostat approximately 2-1/2 inches (64 mm) to either side of the oil heater and 2-1/2 inches (64 mm) above the heater. See Fig. 6.

NOTE: Remote thermostats require a wide variety of thread sizes. To find the thread size needed for your thermostat model, call HOTSTART.

Figure 6. Possible thermostat installation areas. Note the minimum oil level.

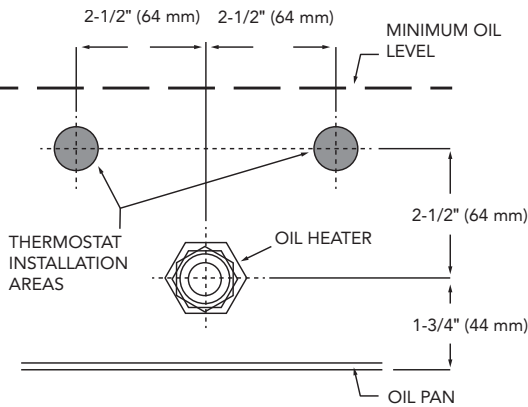

WIRING THE HEATER & THERMOSTAT

CAUTION

Personal Injury: Disconnect power supply before performing any electrical work. Wiring must be performed by a trained technician and in accordance with national and local electrical codes.

NOTE: The thermostat must be wired in series with the heater to regulate temperature. The thermostat is wired in series with the heater in the following steps. See Fig. 7.

Figure 7. Heater and remote thermostat wiring schematic.

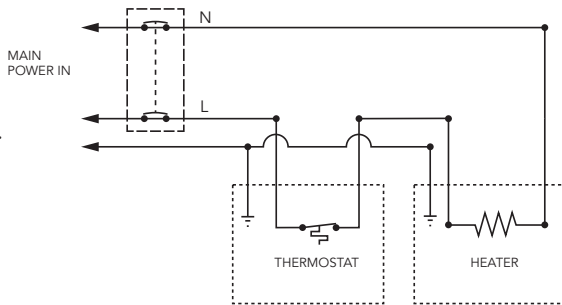

1. Starting from the end of the thermostat cord, split apart each wire into 4 inch (102 mm) segments. Strip the conductor ends approximately 1/2 inch (13 mm). See Figure 8.

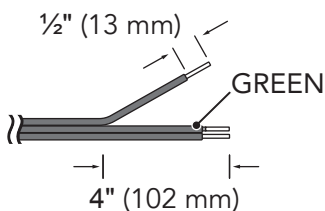

Figure 8. Heater and remote thermostat wiring schematic.

2. Select a point along the heater cord where the thermostat cord will be connected. Ensure the thermostat cord is long enough to reach the connection point.
3. At the selected point of the heater cord, cut the green wire and one power lead. Split apart each wire on both sides into 4 inch (102 mm) segments. Strip the conductor ends approximately 1/2 inch (13 mm). See Fig. 9.

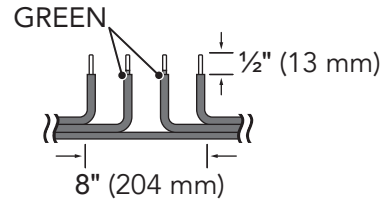

Figure 9. Heater and remote thermostat wiring schematic.

4. Using appropriately rated connectors, splice the wires together. Wrap splice with electrical tape to protect the splice and reduce strain. See Fig. 10.

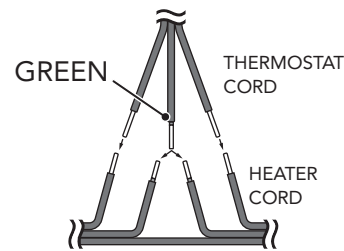

Figure 10. Heater and remote thermostat wiring schematic.

NOTE: It is not necessary to note the polarity of the thermostat wires. Either thermostat power lead can be spliced to either heater power lead without affecting the performance of the heater or thermostat.

NOTE: Models designated for Hazardous Locations (with the prefix "OE-") have a termination enclosure to meet NEC Class I, Division 1, Group D requirements when wired in compliance with NEC specifications.

HEATER & THERMOSTAT PARTS

HEATERS

Weathertight models

Weathertight heaters (with the prefix "OW-") as shown in Fig. 11 have the following replacement parts available (sold separately):

- Heater
- Straight cord (without thermostat)
- Y-cord (with thermostat) See Fig. 11.

Class I, Group D models

Class I, Group D heaters for Hazardous Locations (with the prefix "OE-") are sold as a complete assembly only. Replacement parts are not available for these models.

THERMOSTATS

Thermostat sensing units have a finite life. HOTSTART recommends that thermostat sensing units be replaced every 3 years or 25,000 hours of operation. For all replacement part details and specifications, call HOTSTART.

Weathertight models and Class I, Group D models

Weathertight and Class I, Group D thermostats have the following replacement parts available (sold separately):

- Thermostat well
- Thermostat sensing unit

To remove and replace a thermostat sensing unit, use the following steps:

1. Remove the well. For Weathertight models, unscrew the hex cap. For Class I, Group D models, unscrew well from housing. See Fig. 12 and Fig. 13.
2. Pull cord from well. Sensing unit will be attached to plug at end of cord.
3. Pull sensing unit off plug.
4. Insert new sensing unit into plug. Spade terminals should not be exposed.
5. Insert new sensing unit and plug into well.
6. Replace the well. For Weathertight models, screw hex cap down. For Class I, Group D models, screw well to housing.

NOTE: To avoid damage to the Weathertight plastic hex cap threading, do not over-tighten

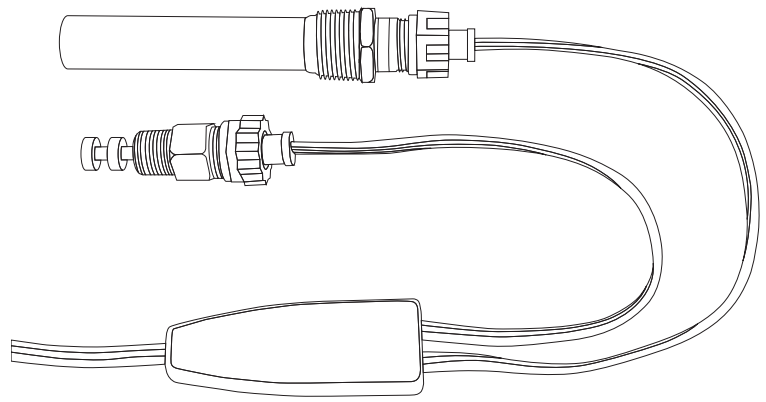

Figure 11. Weathertight oil heaters and thermostats have replacement parts available, including straight cords and Y-cords.

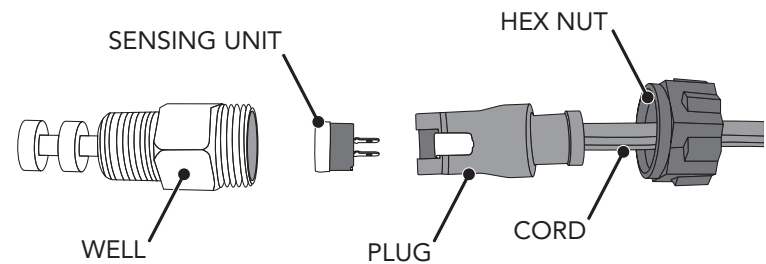

Figure 12. Exploded diagram of a Weathertight thermostat assembly, showing sensing unit replacement part.

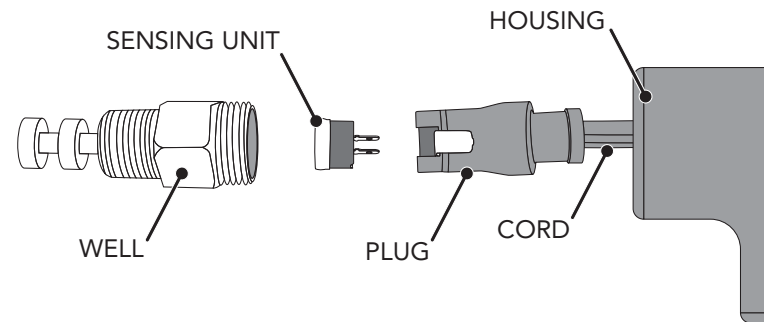

Figure 12. Exploded diagram of a Class I, Group D thermostat assembly, showing sensing unit replacement part.